



SOLAR ENERGY

EMAX CYLER CYLINDRICAL SOLAR PANEL



Module number	EMAX CYLER-140W	EMAX CYLER-100W
Peak power / Pm(W)	140±5%	100±5%
Open circuit voltage / Voc(V)	21.6	21.6
Max. power voltage / Vmp(V)	18	18
Max. power current / Imp(A)	7.78	5.56
Short circuit current / Isc(A)	8.56	6.11
Solar cells efficiency	over 20.8%	
Grade of solar cells	A grade	
Dimensions(L*W*T) / Weight(kgs)	1560*228*200mm /28kgs	1160*228*200mm /21.7kgs
Solar cell / Size of solar cells /solar cells arrangement	monocrystalline silicon 39.1875*78.375*0.19mm/1*36,36-cell in series	
Front cover(material/thickness)	Low-iron tempered glass / 3.2mm	
Encapsulation(material)	Ethylene Vinyl Acetate(EVA)	
Solar backsheet(material/color)	TPT / White-color(black color is optional)	
Frame(material/color)	Anodized aluminium alloy / Silver	
Standard Testing Conditions	Irradiance:1000W/m ² , Cell temperature:25°C, AM:1.5(air mass).	
Max. hailstone impact (diameter/velocity)	25mm; 23m/s	
Max. system voltage (V)	1000V DC	
Application Class	Class A	
Operating temperature range	-40°C- +85°C	
NOCT	45±2°C	
Power temperature coefficient	-0.43%/°C	
Current temperature coefficient	0.08%/°C	
Voltage temperature coefficient	-0.37%/°C	
Lifespan	25 years	
Warranty	Power output warranty: 10 years over 90%, 25 years over 80%;	
Product Certifications / Standards	CE, IEC61215	
Other Certifications	ISO9001:2008, RoHS	





SOLAR ENERGY

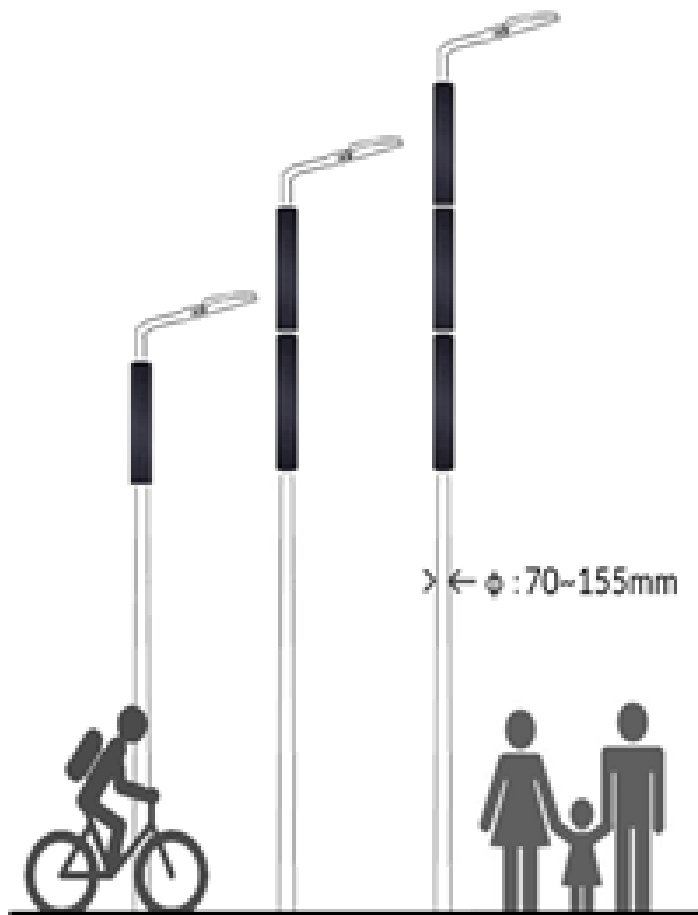

EMAX CYLER 100-W

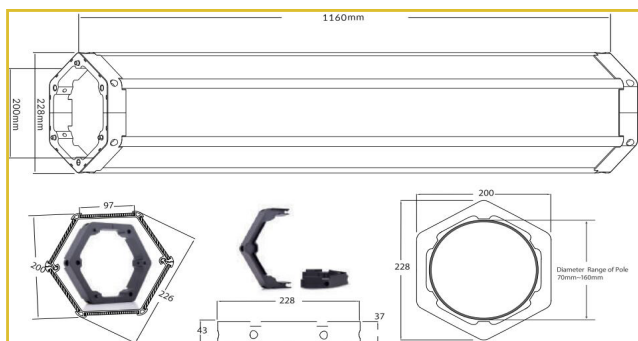

EMAX CYLER 140-W

